

OPX REC

THERMAL OIL GENERATOR

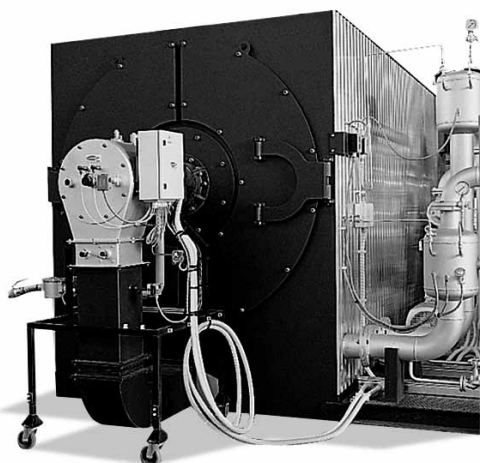

Main features

The OPX REC thermal oil generator has 3 smoke ways, passing flame combustion chamber conveyed into a heat recovery unit. Is designed for low thermal loads and high oil speeds in order to eliminate any risk of cracking, namely the process of oil thermal decomposition when the oil is subjected to overheating.

In addition, the very low thermal capacity, due to reduced use of refractory cements, involves a high degree of reliability against the risk of overheating even in cases of oil circulation arrest.

Some of the product's main features are related below:

- Diathermic fluid heat generator, horizontal axis coil, spiral warped
- Fe 35 UNI 663/68 carbon steel, "MANNESMANN" quality S. S. tube coils built curved with multiple tangent spirals, various combustion gas revolutions being separated.
- carbon steel boiler support able to ensure whole group support; a service platform is provided laterally along with the diathermic fluid circulation group
- bolted front door, easily opened for inspection and cleaning, equipped with cone burner and combustion control light.
- external high density, mineral wool thermal insulation, with aluminum finish sheet mounted on a rectangular frame
- fumes connection to flange exhaust, housed in the upper fumes chamber, bolted to the boiler and easily removable for cleaning operations.
- combustion air preheater installed in the rear part of the generator so as to form a single unit consists of:
 - AISI 304 stainless steel tube bundle with vertical tubes and expanded tube plates
 - hot fumes collecting chamber and outlet fitting for cold smoke
 - Fume collection hood with two cleaning and inspection doors and a wide rear opening for the preheater
 - cold air intake fitting with flow that surrounds the tube bundle and crosses it in counter-current
 - hot air conduction duct incorporated into generator structure in order to bring air in front of the combustion.

Standard equipment:

- 2 input output connections complete with counter flanges
- boiler drain valve
- 2 steel aerator valves
- 2 oil input output manometers complete with steel shut-off valves
- liquid expansion security thermostat with manual restart
- boiler oil circulation security differential pressure gage complete with steel valves
- fumes security probe
- oil circulation unit containing:
 - electric pump directly coupled to a jointed electric motor, cast iron body, steel shaft with auto cooling mechanical seal, placed on a pedestal.
 - 2 flow start valves in spherical cast iron with sealing metal bellows, mounted on suction and delivery.
 - steel filter mounted on pump suction
 - 2 stainless steel expansion compensators mounted on pump suction and delivery
- boiler electric command panel, IP 55 electrical protection, composed of:
 - main switch
 - oil circulation pump command interrupt (off-manual-automatic)
 - burner command switch
 - oil temperature electric regulator
 - high oil pressure light and alarm reset button
 - low oil circulation pressure light and alarm reset button
 - high fumes pressure light and alarm reset button
 - alarm siren

Accessories:

- EVX indirect steam generator
- PMX oil circulation unit
- VEO oil expansion tank

For each product always indicate the code at the time of the order.

INDUSTRIAL RANGE

THERMAL OIL OPX REC

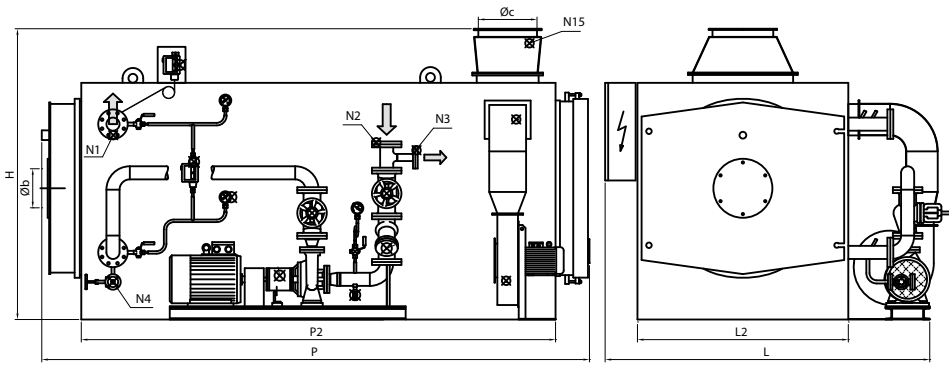

- Legend:**
 N1 Diathermic oil delivery
 N2 Diathermic oil return
 N3 Expansion vessel connection
 N4 System drain
 N15 Fumes temperature control

Characteristics	Code product	Effective capacity kW	Flow Thermal kW	Oil side pressure drop ($\Delta T=40^{\circ}C$) bar	Maximum working temperature TS $^{\circ}C$	Total volume H ₂ O lt	Fumes pressure drop mbar	Fuel consumption			Total weight kg
								Gas Nm ³ /h	Diesel fuel kg/h	Nafta kg/h	
OPX 1000 REC	87111001	1163	1277	1,68	300	460	5,5	130,7	107,6	113,2	3500
OPX 1200 REC	87111201	1395	1533	1,00	300	680	6,0	156,9	129,2	135,9	4800
OPX 1500 REC	87111501	1744	1916	1,70	300	700	7,5	196,2	161,6	169,9	5000
OPX 2000 REC	87112000	2326	2555	1,60	300	1350	8,0	261,5	215,4	226,5	6800
OPX 2500 REC	87112501	2907	3194	1,30	300	1600	9,0	327,0	269,3	283,2	8600
OPX 3000 REC	87113000	3488	3833	1,80	300	1520	10,0	392,4	323,1	339,8	10500
OPX 4000 REC	87114000	4651	5110	2,00	300	2300	12,0	523,2	430,9	453,1	14000
OPX 5000 REC	87115000	5814	6388	1,90	300	2500	15,0	654,0	538,6	566,4	15000
OPX 6000 REC	87116000	6977	7666	2,00	300	2800	18,0	784,9	646,4	679,7	21000
OPX 8000 REC	87118000	9302	10222	2,90	300	3650	19,0	1046,5	861,9	906,3	28000

Dimensions	H	H1	H2	L	L2	L4	P	P2	$\varnothing b$	$\varnothing c$	N1	N2	N1/N2	N3	N4	N15
Model	mm	mm	mm	mm	mm	mm	mm	mm	mm	mm	DN/in	DN/in	PN	DN/in	DN/in	in
OPX 1000 REC	2000	1605	890	2150	1430	1715	3800	3420	280	400	80	80	16	40	20	1/2"
OPX 1200 REC	2120	1715	935	2300	1560	1845	4300	3870	320	450	100	100	16	50	20	1/2"
OPX 1500 REC	2250	1850	1000	2500	1650	1935	4600	4000	320	500	100	100	16	50	20	1/2"
OPX 2000 REC	2700	2350	1350	2700	2100	2250	4700	4628	350	550	125	125	16	50	20	1/2"
OPX 2500 REC	2900	2500	1400	2900	2200	2350	5200	4976	360	600	125	125	16	50	20	1/2"
OPX 3000 REC	2850	2450	1350	3000	2300	2474	5600	5394	380	600	150	150	16	50	20	1/2"
OPX 4000 REC	3300	2850	1650	3300	2500	2650	6350	6152	400	650	150	150	16	65	32	1/2"
OPX 5000 REC	3800	3200	1800	3450	2800	2950	7000	6278	400	700	200	200	16	65	32	1/2"
OPX 6000 REC	3800	3200	1800	3600	2800	2950	7750	7028	400	800	200	200	16	65	32	1/2"
OPX 8000 REC	3800	3200	1800	3750	2800	2950	8000	7278	450	850	200	200	16	65	32	1/2"